

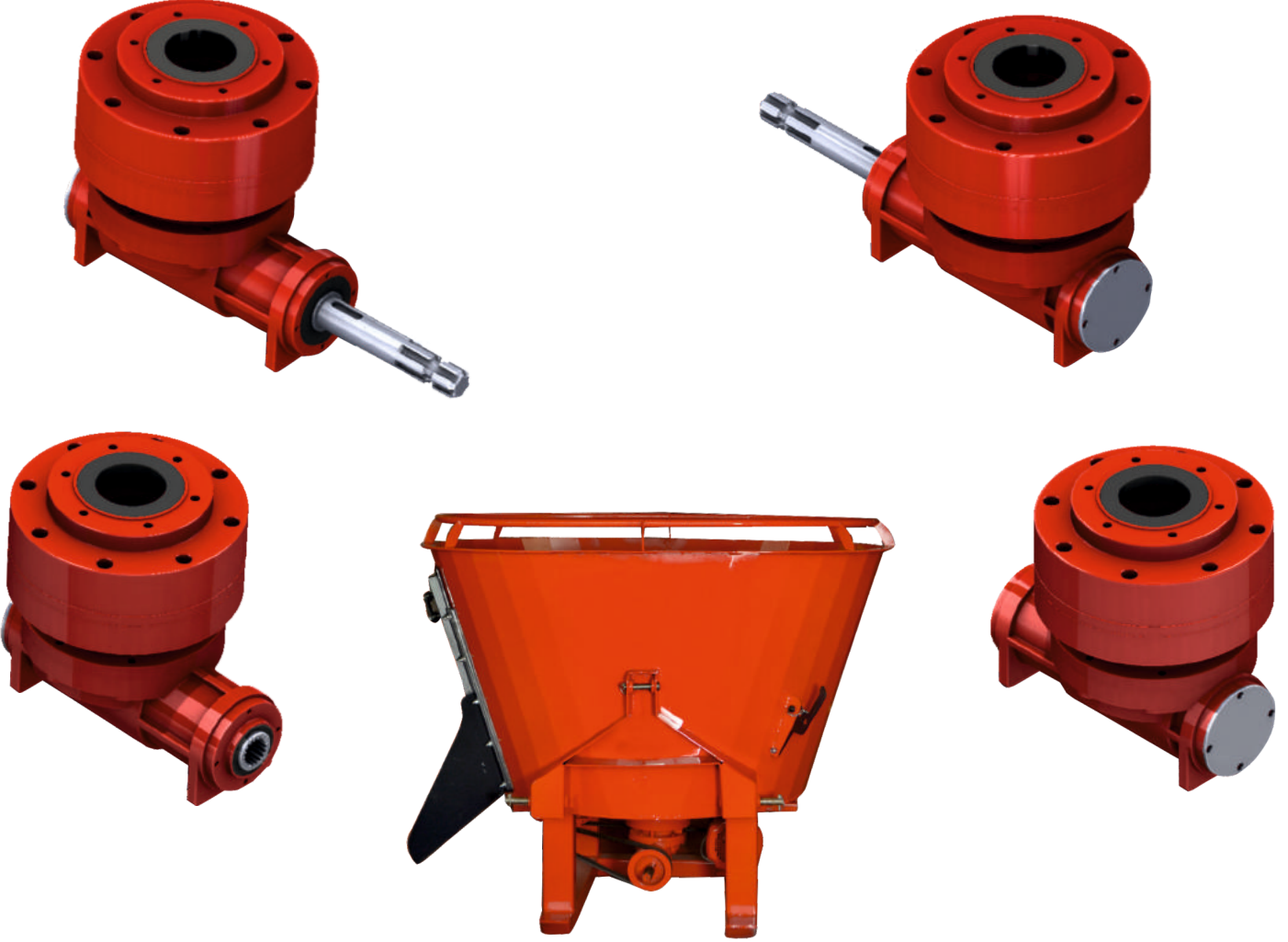

REMAK

Redüktör

YEM KARMA ŞANZIMANI OLARAK KULLANILMAKTADIR.
AYNA MAHRUTİ PLANET ŞANZIMANIDIR.



ÜRÜN NO : YEM KARMA

ÖZELLİKLER

Çevrim Oranı: 1/10.5

Giriş devri : 540 r.p.m

Çıkış devri : 51.4 r.p.m

ÜRÜN NO : YEM KARMA (HİDROMOTOR UYUMLU)

ÖZELLİKLER

Çevrim Oranı: 1/10.5

Giriş devri : 540 r.p.m

Çıkış devri : 51.4 r.p.m

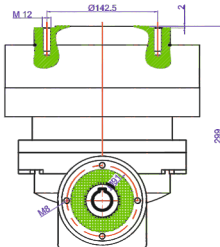
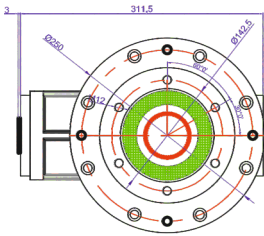

REMAK
REDÜKTÖR

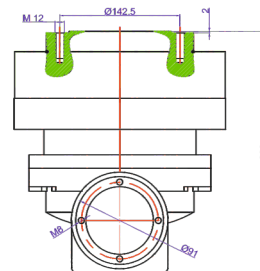
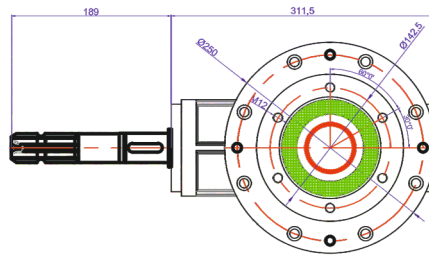

REMAK
REDÜKTÖR

RS

KATI GÜBRE SAVURMA - ÇAPALAMA ŞANZIMANI OLARAK KULLANILMAKTADIR.

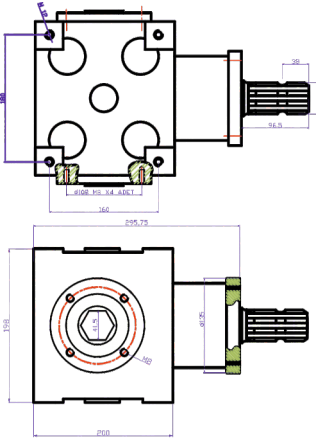
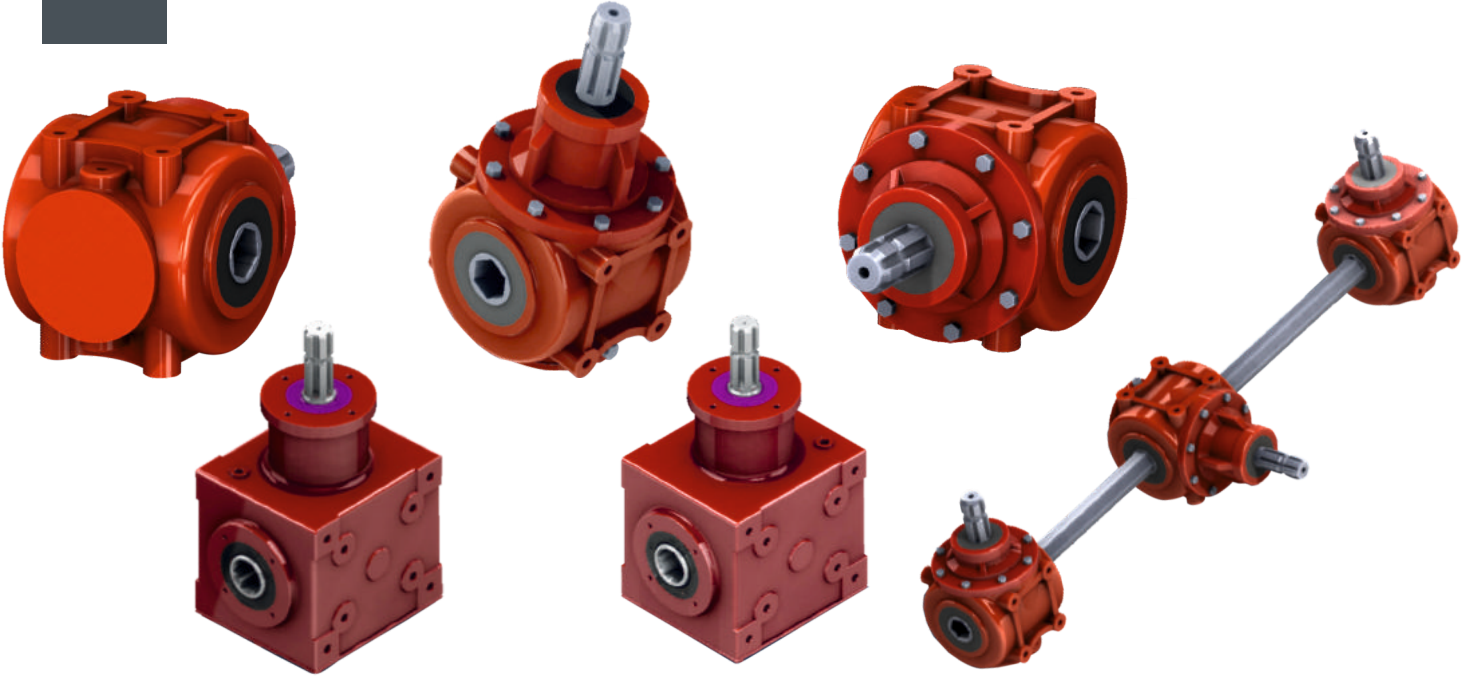

ÜRÜN NO : RS-01

ÖZELLİKLER

Çevrim Oranı : 1/1,45

Giriş devri : 540 r.p.m

Çıkış devri : 372 r.p.m

Kullanım alanı : Kat gübre dağıtma römorku

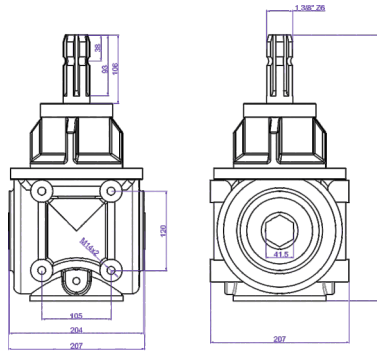

ÜRÜN NO : RS-02 UZUN FLANŞ

ÖZELLİKLER

Çevrim Oranı : 1/1,61

Giriş devri : 540 r.p.m

Çıkış devri : 335 r.p.m

Kullanım alanı : Kat gübre dağıtma römorku

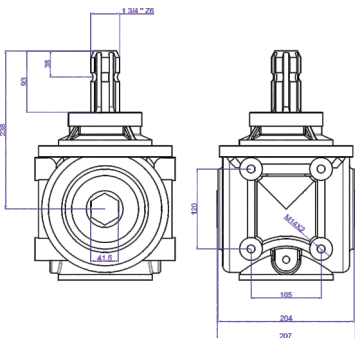

ÜRÜN NO : RS-02 KISA FLANŞ

ÖZELLİKLER

Çevrim Oranı : 1/1,61

Giriş devri : 540 r.p.m

Çıkış devri : 335 r.p.m

Kullanım alanı : Kat gübre dağıtma römorku

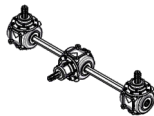

RK

TOPRAK ÇAPALAMA - ROTAVATÖR
ÇALI KIRMA MAKİNALARINDA KULLANILMAKTADIR.
KONİK AYNA MAHRUTİ DİŞLİDİR.
DİŞLİLER ISIL İŞLEM GÖRMÜŞ VE SERTLEŞTİRİLMİŞLERDİR.

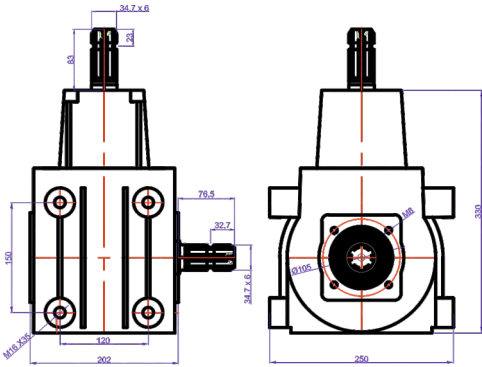
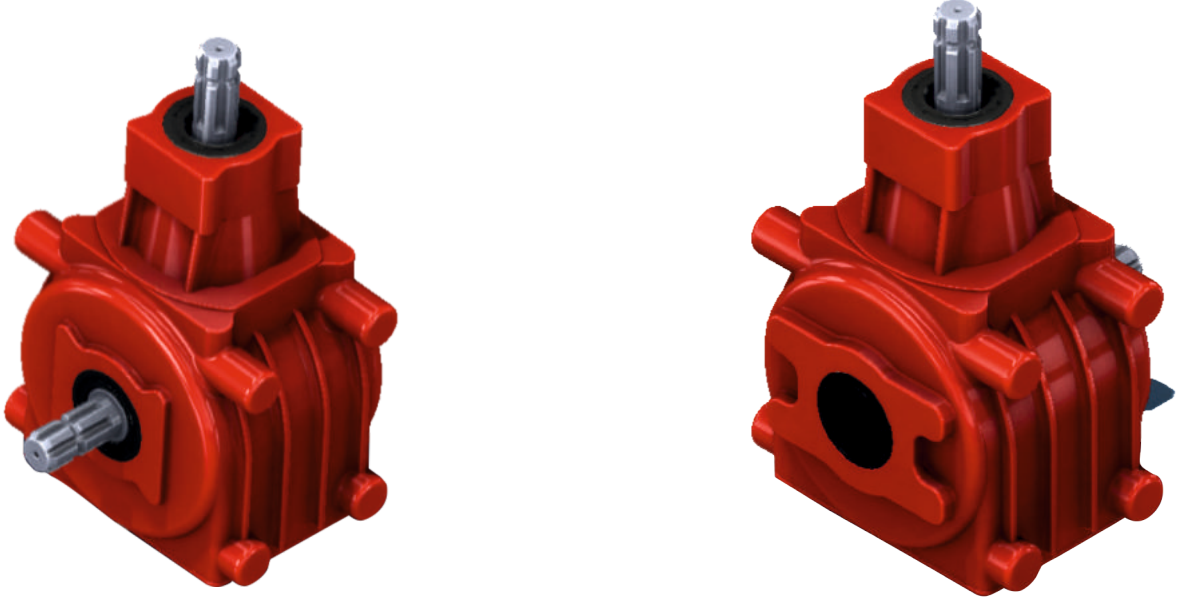

ÜRÜN NO : RKA-01 (AYNA MAHRUTİ)

ÖZELLİKLER

Çevrim Oranı : 1/2.58

Giriş devri : 540 r.p.m

Çıkış devri : 209 r.p.m

Kullanım alanı:Çalı çrpma

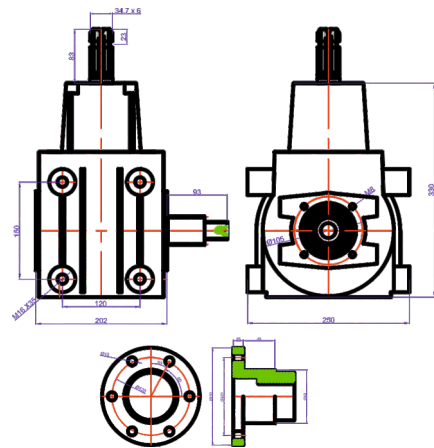

ÜRÜN NO : RK-01 (KONİK DÜZ DİŞLİ)

ÖZELLİKLER

Çevrim Oranı : 1/3.1

Giriş devri : 540 r.p.m

Çıkış devri : 209 r.p.m

Kullanım alanı:Çalı çrpma

MOTORLU SEPERATÖR ŞANZIMANI OLARAK KULLANILMAKTADIR.

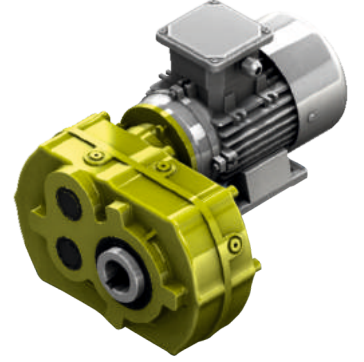
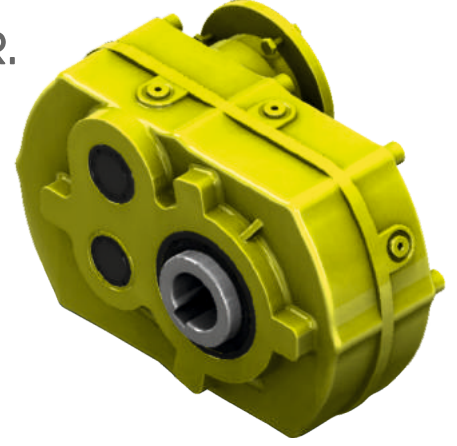
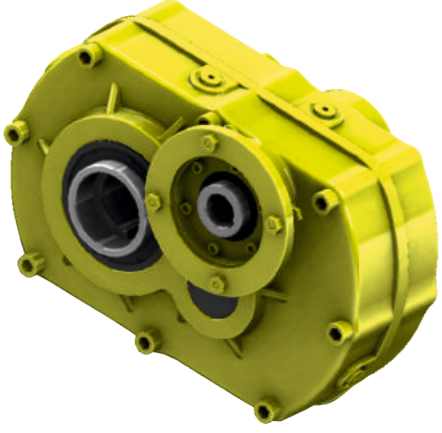

ÇIKIŞ MİLİ ÖLÇÜLERİ

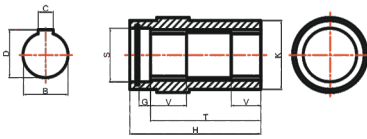

	B	C	D	G	K	H	S	T	V
RDX 1	25	8	28	10	55	134			
RDX 1	30	10	33,4	10	55	134			
RDX 1	35	10	38,4	10	55	134			
RDX 2	40	12	43,4	12	65	136	40	110	40
RDX 2	45	14	48,6	12	65	136	50	129	30
RDX 3	45	14	48,6	12	75	170	50	129	30
RDX 3	50	14	53,6	14	75	170	60	142,5	35
RDX 3	55	16	58,9	14	75	170	60	142,5	35
RDX 4	55	16	58,9	14	85	189	65	142,5	35
RDX 4	60	18	64,3	14	85	189	60	175	50
RDX 4	65	18	69,3	14	85	189	65	175	50
RDX 5	65	18	69,3	14	95	198	70	175	50
RDX 5	70	20	74,7	16	95	198	70	185,5	60
RDX 5	75	20	79,7	16	95	198	85	185,5	60
RDX 6	75	20	79,7	16	120	208	85	208	50
RDX 6	80	20	84,7	16	120	208	100	208	50
RDX 6	85	20	89,7	16	120	208	95	226,5	55
RDX 7	90	25	95,6	20	140	240	120	226,5	55
RDX 7	95	25	100,6	20	140	240	120	302	60
RDX 7	100	28	106,2	20	140	240	145	302	60
RDX 8	100	28	106,2	22	155	406	145	302	60
RDX 8	105	28	111,2	22	155	406	145	302	60
RDX 8	110	28	116,2	22	155	406	145	302	60

RDX GÖVDE ÖLÇÜLERİ

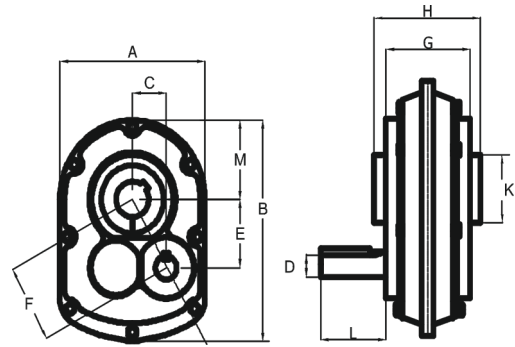

	A	B	C	M	E	F	G	H	K	L	D
RDX 1	180	253	49	96	81	94,66	114	134	55	60	19
RDX 2	210	289	55	105	96	110,64	116	136	65	75	28
RDX 3	242	330	62	124	108	124,53	150	170	75	90	32
RDX 4	265	385	70	140	122	140,65	159	189	85	100	40
RDX 5	334	480	77	178	144	149,18	168	198	95	110	48
RDX 6	385	542	104	192	171	200,14	178	208	120	120	55
RDX 7	477	660	130	239	211	247,83	200	240	140	130	60
RDX 8	515	718	153	257	241	285,46	356	396	155	140	65

HİDROLİK POMPA ŞANZIMANI OLARAK KULLANILMAKTADIR.

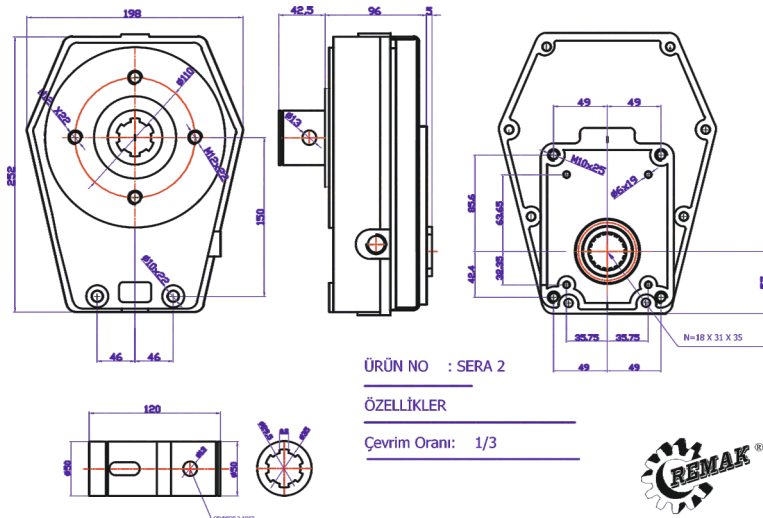
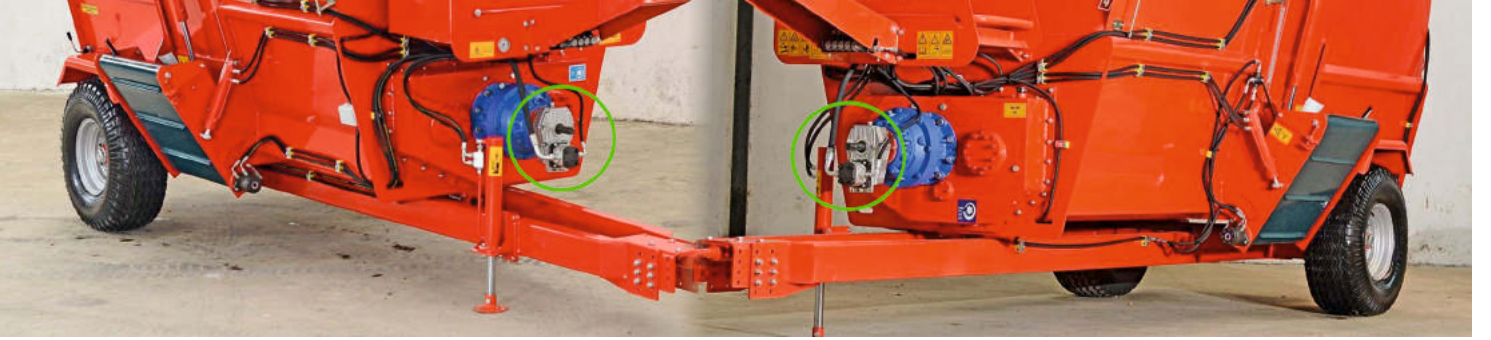
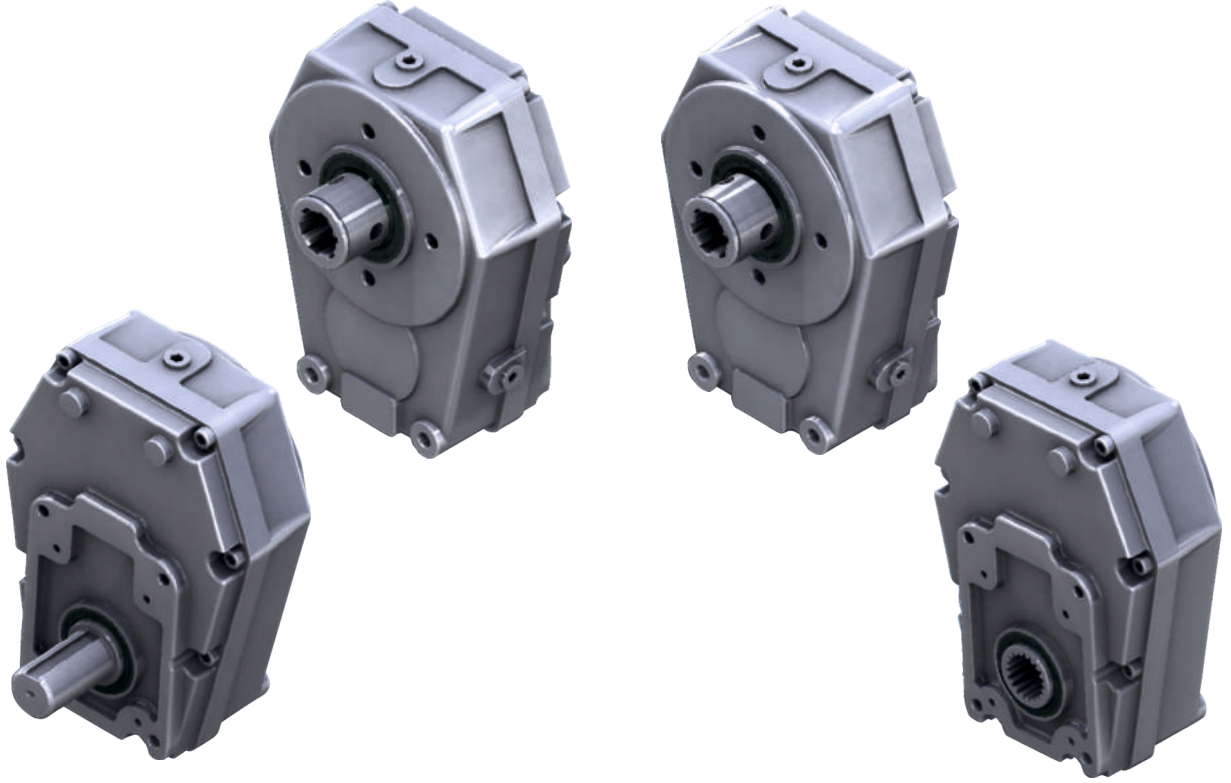



KATI GÜBRE SAVURMANIN RÖMORK ZEMİNİ
ŞANZIMANI OLARAK KULLANILMAKTADIR.

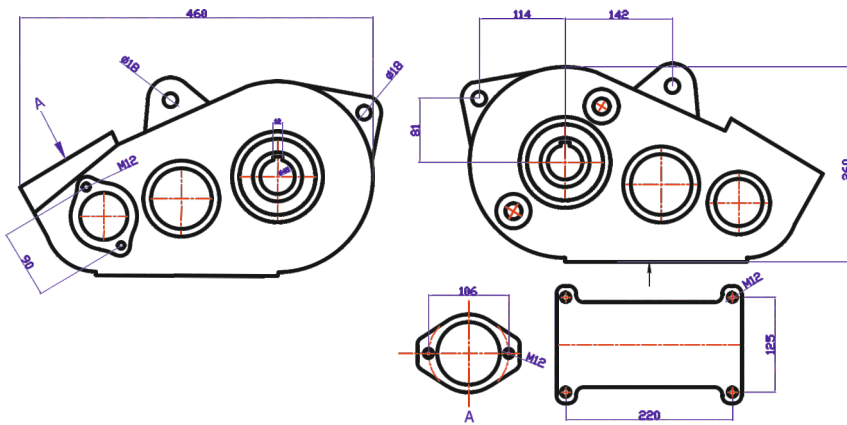

ÖZELLİKLER

Çevrim Oranı: 1/28 , 1/17.5

Giriş devri : 540 r.p.m

Çıkış devri : 19 , 31 r.p.m

Kullanım alanı : Kati gübre dağıtma römorku



HAYVAN KAŞIMA FIRÇA
ŞANZIMANI OLARAK KULLANILMAKTADIR.
İSTENİLDİĞİ TAKDİRDE KOMPLE HAYVAN KAŞIMA
SETİ OLARAK FIRÇASI İLE VERİLMEKTEDİR.

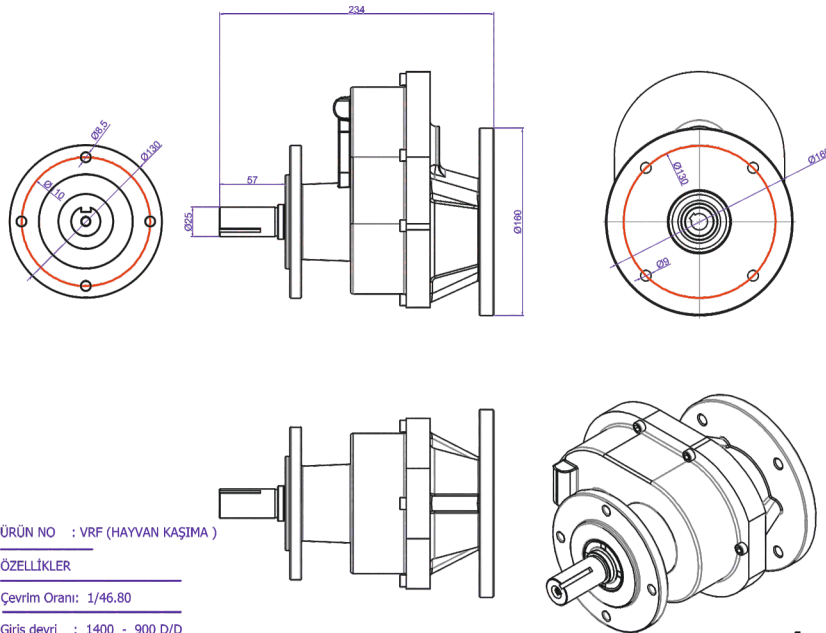
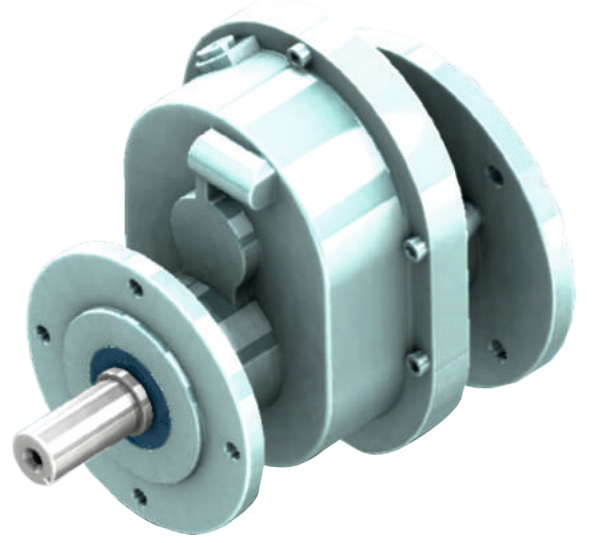
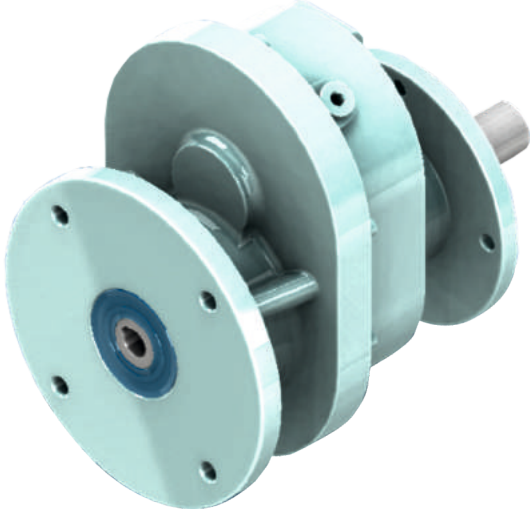

ÜRÜN NO : VRF (HAYVAN KAŞIMA)

ÖZELLİKLER

Çevrim Oranı: 1/46.80

Giriş devri : 1400 - 900 D/D

Çıkış devri : 30 - 19.20 D/D

Kullanım alanı:

AT

GÜBRE SIYIRMA
ŞANZIMANI OLARAK KULLANILMAKTADIR.

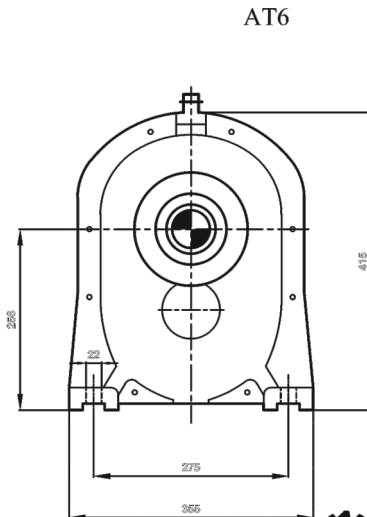
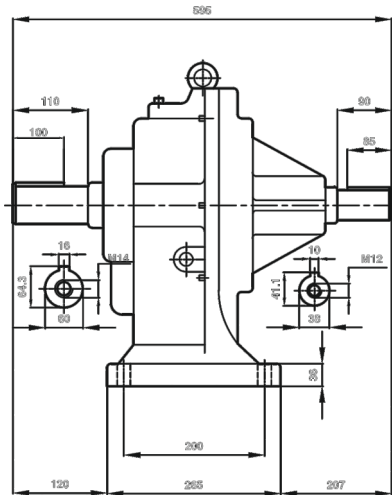
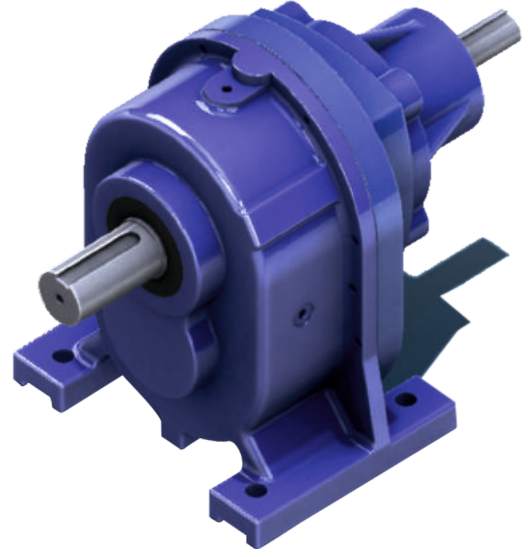

AT6



SIYIRGAÇ
ŞANZIMANI OLARAK KULLANILMAKTADIR.

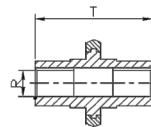
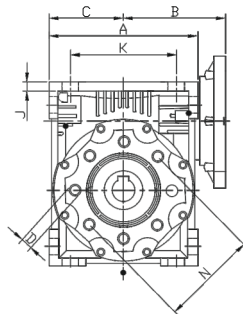
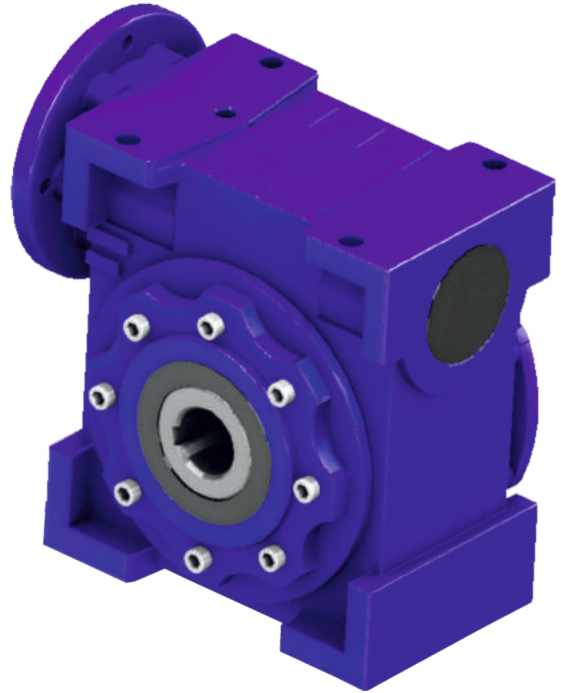
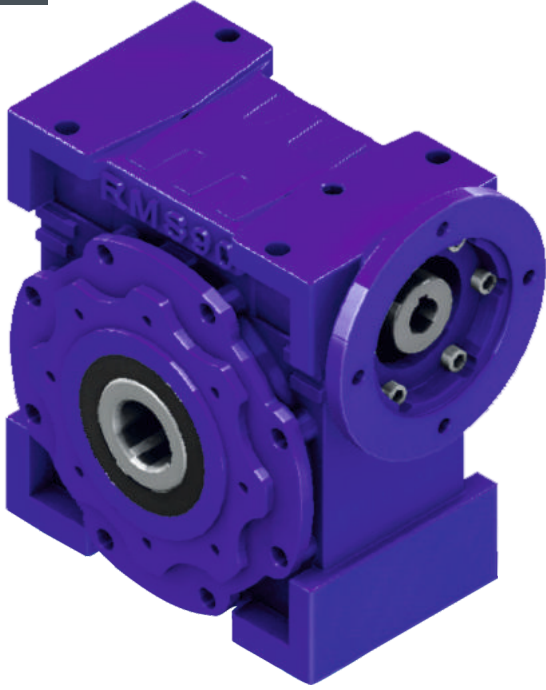

REMAK
REDÜKTÖR

TİP	A	B	C	D	E	F	G	H	I	J	K	L	M	N	O	P	R	S	T
RMS90	206	131	103	M8x18	101	135	236	70	102	11	140	110	90	130	100	13	35	10	140
RMS110	289	162	127	M8x18	130	164	294	85	126	15	170	130	110	164,5	115	14	42	12	170
RMS130	332	184	148	M8x21	148	188	336	100	141	16	200	180	130	215	120	16	45	14	170
RMS160	360	201	159	M8x21	165	250	415	115	170	17	232	200	160	290	144	16	50	14	208

MOTOR PLANET

GÜBRE KARIŞTIRMA PLANET
ŞANZIMANI OLARAK KULLANILMAKTADIR.

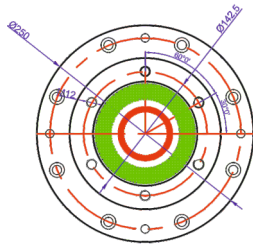
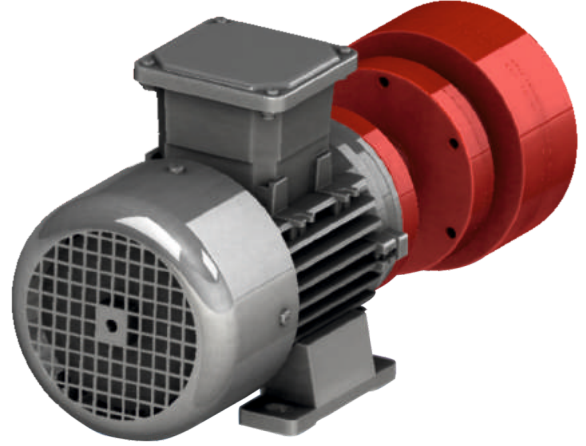
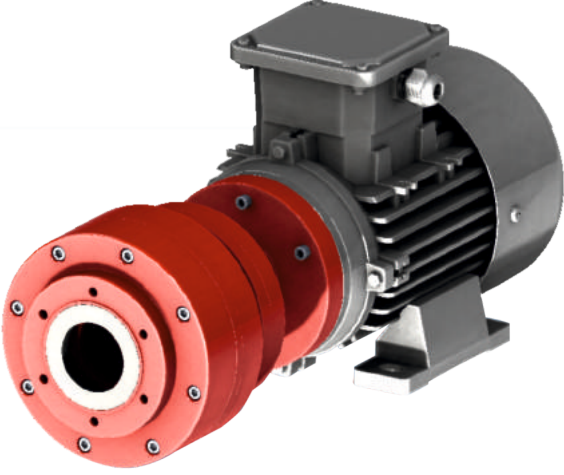

ÜRÜN NO : MOTOR PLANET

ÖZELLİKLER

Çevrim Oranı : 1/5,5

Giriş devri : 540 r.p.m

Çıkış devri : 98 r.p.m

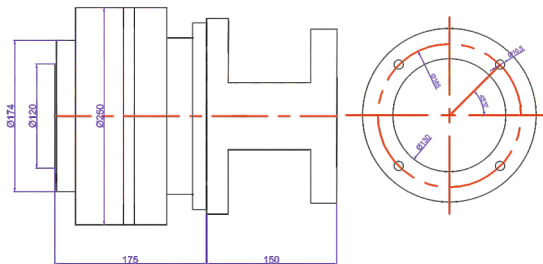
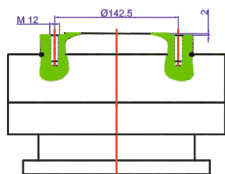



REMAK Redüktör



RemakReduktor.com.tr



Kemalpaşa Organize Sanayi
Bölgesi Kuyucak Yolu
Caddesi No:211
Kemalpaşa / İzmir



info@remakreduktor.com.tr



0 (232) 479 68 48-49

Önce Kalite ...



Güçlü ve Güvenilir

Çözüm Ortağınız ...



Gelecekte Güven Duyulan Ürünler

Satış Sonrası Destek



İnsana ve Çevreye
Duyarlı Üretim

